

# FIDO'S<sup>®</sup>

## COMMERCIAL HYDROBATH

Single Tank, Twin Filter, Bypass To Drain Model With Heater

### Key to Commercial Hydrobath components

*Congratulations on the purchase of your new Fido's Commercial Hydrobath. We hope this instruction sheet and product listing will help provide you with many years of trouble free operation.*

*Fido's Hydrobaths are equipped with a 3/4HP Davey centrifugal pump delivering through the shower rose 20L/min at 150KPA pressure. They have a "Rilsan" pump housing which is resistant to most chemicals and give years of trouble free operation.*

**NB: NO FIDO'S PRODUCTS HAVE HARSH CHEMICALS, THEY ARE ALL WATER BASED.**

1. Thermostat controls the temperature, to which the water in the tank is heated.
2. Heater switch, switches the heater on and off.
3. Pump switch, switches the pump on and off.
4. Shower hose/rose connection point.
5. Entry door
6. Waste outlet.
7. 240V electrical cord with 3 pin plug and "Lifesaver" safety switch.
8. Tank for holding water. Contains a heating element, and essential low water cut-out switch. Holds 34 litres. Always fill at least above the nylon bag filter. Washing involves recycling to and from the tank.
9. Heating element. (Warranty for 6 Months only)
10. Low water cut-out switch.
11. Bypass-to-waste drain hole.
12. Nylon bag filter to pick up finer residue from hydrobathed dog as recycling takes place.
13. Recycle-to-tank drain hole.
14. Metal filter on tank pump inlet side to protect pump.
15. To waste drain hole.
16. Lid for covering tank whilst hydrobathing.
17. Tie point (Accessory item).
18. The shower hose/rose, the real key to superior washing.

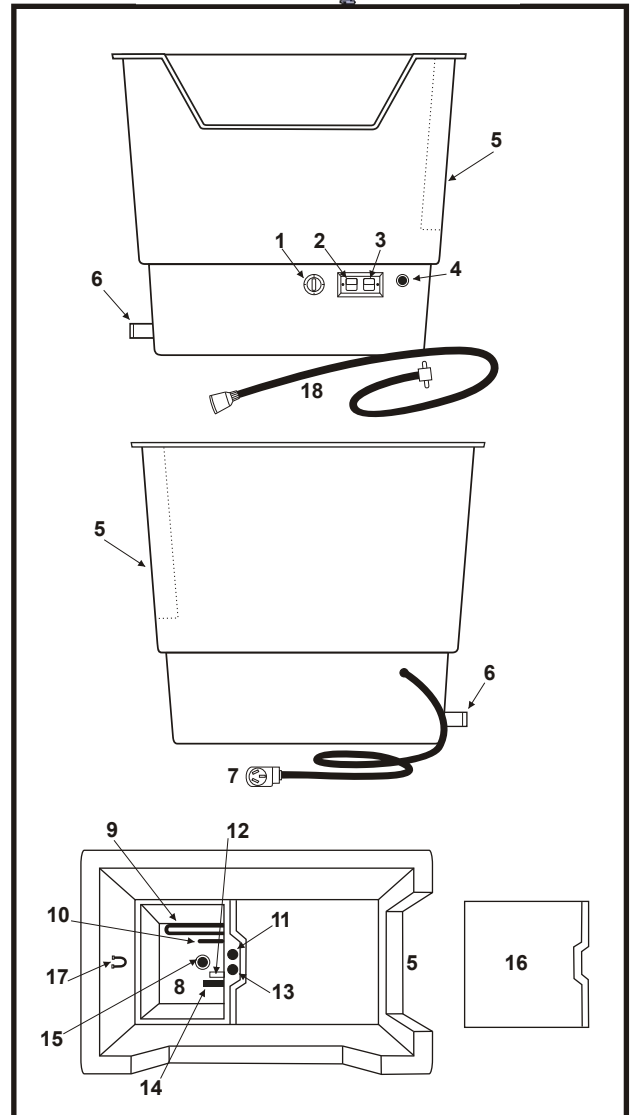

Model No.: \_\_\_\_\_

Serial No.: \_\_\_\_\_

Date Purchased: \_\_\_\_\_

Added Extra's:

1. \_\_\_\_\_
2. \_\_\_\_\_
4. \_\_\_\_\_
5. \_\_\_\_\_



We Do Care

Customer Service  
 Shirley McCormack Phone 07 3808 1399  
 National Sales Manager  
 Martin Davis Ph 0403 577 417

See us on the web  
[www.fidos.com](http://www.fidos.com)

## INSTRUCTIONS FOR USING FIDO'S COMMERCIAL HYDROBATH

- A.** Position the hydrobath on a level surface. Remove lid **16**.
- B.** Connect the shower hose/rose **18** to point **4**.
- C.** Make sure the drain plugs **11** and **15** are in place and the filter bag is on outlet **12**.
- D.** Manually fill the tank with water as required but at least to well cover the metal filter and pump inlet.
- E.** Plug in **7** to a 240V approved electric power outlet.
- F.** Set the thermostat control **1** at the desired temperature.
- G.** Turn on the heating switch **2**.
- H.** Put Fido's Rinse Concentrate into the tank.
- I.** Take the shower hose/rose **18** in hand and turn on the pump switch **3**.  
Check the temperature by feeling the water. Turn off the pump.
- J.** Put the lid **16** back on top of the tanks and if appropriate attach the dog to the tie point **17**.
- K.** To wash the dog turn on the pump switch **3** and move the rose through the coat to remove the accumulated dirt, fleas and excess sebum.
- L.** You may now wish to drain the dirty water from the tank. To do this close the drain hole **13**, open drain hole **11** and pump the water from the tank to waste.
- M.** To rinse the dog in clean water manually fill with clean water as in 'D'.
- N.** On completion of the hydrobathing, switch off both the pump switch **3** and heater switch **2**, and the electric power. **Never run the pump dry.**
- O.** At the end of the day fill the tank with water, add Fido's Hydrobath Flush disinfectant and run the pump for 15 seconds. This cleans and sanitises the tank, the pump, the drain lines and the shower rose. Clean the hair and other debris from the nylon bag filter and replace when necessary. Wipe over with a damp cloth or clean with a liquid washing up detergent only. Scratches can be rubbed out with Brasso.

## PRODUCTS AVAILABLE FOR YOUR HYDROBATH

### RINSES

*These are "leave in" products which can be used subsequent to shampooing for their flea and tick control/conditioning properties, or on their own as an alternative to the shampooing process.*

### Flea and Tick control

#### FIDO'S FRE ITCH RINSE CONCENTRATE

Our top selling product. A pleasant smelling product of proven effectiveness against ticks and fleas. Based on the natural insecticide, pyrethrin. Safe to use in combination with long term flea control products. Safe for use in dogs and cats of all ages.



#### FIDO'S PERMETHRIN RINSE CONCENTRATE

Controls fleas, ticks and flies in dogs and horses. Based on the man-made insecticide, permethrin.

### Non-Insecticidal

#### FIDO'S HERBAL RINSE CONCENTRATE

A leave in conditioner with a pleasant perfume which lasts for days on the coat.



### SHAMPOOS

### Flea and Tick Control

#### FIDO'S FRE ITCH FLEA SHAMPOO

A carbaryl based shampoo for flea and tick control in dogs and cats. Use weekly. Available in 250mL, 500mL & 5Litre.

#### FIDO'S FRE ITCH PYRETHRIN SHAMPOO

A soap free shampoo containing the natural insecticide pyrethrin. Safe for use with long term flea control treatments. Available in 250mL, 500mL & 5Litre.



### Non-Insecticidal

#### FIDO'S EVERYDAY SHAMPOO

A mild soap free, hypoallergenic shampoo. Can use as often as desired without stripping the coat of its natural oils.

#### FIDO'S HERBAL SHAMPOO

A mild, soap free shampoo containing a selection of herbs and oils to clean and condition the coat.



#### FIDO'S ALOE VERA SHAMPOO

A soap free moisturising shampoo containing 10g/L of aloe vera gel. Especially suitable for sensitive skins.

#### FIDO'S PUPPY AND KITTEN SHAMPOO

A cleaning and conditioning shampoo especially formulated for puppies and kittens.

## TROUBLESHOOTING

*Problems are rare and can usually be solved easily. We love to help, but have a read of this first.*

PROBLEM	SOLUTION
The pump is switched on, but the water pressure is low or non-existent.	A common cause is an air-lock because the pump may have been pumped dry or the hydrobath may not have been on a level surface. Fill the tank with water, lay the hose on the ground and allow the water to begin to drain out the shower rose. Direct the shower rose into the bath and at the same time quickly switch on the pump. Repeat if necessary.
During the bathing process the tank becomes empty.	Check that the plug(s) in the bottom of the tank and/or the bypass-to-waste drain hole is/are secure and no water is going to waste. Position the plug(s) correctly. When working with long-coated large dogs and a partially filled tank not enough water may be being returned to the tank. Add more water.
The heating element is not working some or all of the time	The heating element and or the thermostat may be burned out. This can be checked by a certified electrician. There is not enough water in the tank or the hydrobath is not level and the low-water cut-out switch is operating. Bring the water up to cover the element completely including whilst the pump is in operation.
There are too many suds.	Too much rinse or shampoo has been added. Use all Fido's products at about 1 in 1000 dilution, which is 1mL per litre. The hydrobath cleans with a combination of rinse/shampoo and vigorous action of the water so less of the product is needed.
A bad odour is experienced when the hydrobath is turned on at the beginning of the day.	The hydrobath was not cleaned out the last time it was used. Disinfect with Fido's Hydrobath Flush as described in the Instructions For Use section.